



# PROGRAMMABLE ACCESSORY BOARD FOR ENERGY ACCUMULATION

## DATASHEET ACC-01

rev 1.0

### INTRODUCTION

When thermoelectric technology is used to power sensors and actuators from environmental temperature gradients, the level of power generation may vary over time or even drop to zero for some time periods. One way to address the problem is to accumulate energy over time, releasing it in bursts as needed for sensor or actuator power. The ACC-01 serves this role and acts as a programmable platform for systems development.

### SYSTEMS APPROACH TO POWER DELIVERY

Thermoelectric (TE) phenomena arise from the intercoupled electrical and thermal currents in a material. A thermoelectric generator is constructed by connecting multiple n-type and p-type thermoelements in electrical series with all elements in thermal parallel between a heat source and a heat sink. The open circuit (unloaded) voltage that is produced will be proportional to the temperature gradient across the device. When the gradient is relatively small, the magnitude of the generated voltage will be small, in many applications, too small to power practical sensors and actuators. In these cases, a voltage boost circuit may be used, such as the VBXXXX family of voltage boost devices from TXL Group which can convert power at input voltages as low as 40 mV to more usable levels such as 3.3 or 5.0 volts. The ACC-01 can accumulate energy at the higher voltage and release it according to a programmed schedule. A circuit schematic of the ACC-01 is shown in Figure 1.

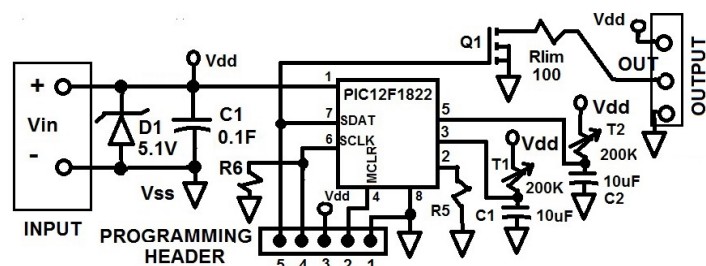

Figure 1 – Electrical Schematic

### PROGRAMMING THE ACC-01

The ACC-01 is under the control of a PIC12F1822 programmable microcontroller manufactured by Microchip. The microcontroller is preprogrammed, however, a programming header is provided to allow user programming. The programming header is provided as five “fingers” with 0.1” spacing as depicted in Figure 2. This lends itself to programming with an edge card connector. Holes in each finger allow the user to install a five pin programming header and, alternatively, to have easy access to the output control line, power, ground and reset.

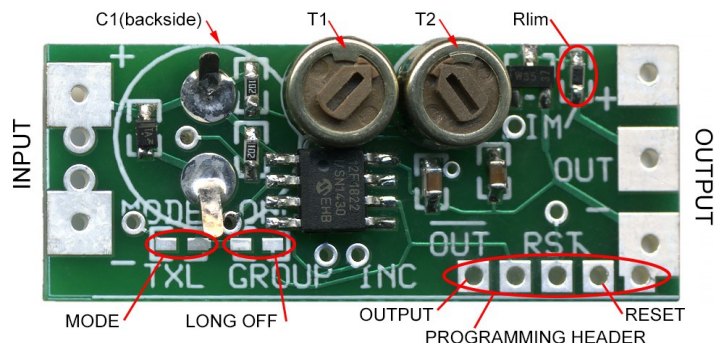

Figure 2 – I/O and Controls

### USER OPTIONS

Without any need for software programming, the user can tailor the ACC-01 for a variety of system duties. There are two general modes of operation, pulse and hysteresis. Pulse mode is the default and corresponds to an open circuit at the MODE position. This corresponds to R5 in the electrical schematic. When a short (or jumper) is applied to this position, for example by soldering a zero ohm resistor, wire, or solder blob, then the unit operates in hysteresis mode. In either of the two modes of operation, specific setpoints may be selected by adjusting the trimmer pots T1 and T2. A user reset is available on the second pin of the programming header. When this pin is tied low, it forces the microcontroller into a reset condition. Since the first (rightmost in Figure 2) pin of the programming header is circuit common, it is a simple matter to apply a momentary short between these two pins to implement a reset. The holes between pins 1 and 2 have a 0.1” spacing into which an industry standard tact switch can be installed for pushbutton reset.

### OPERATIONAL LIMITS

The ACC-01 is designed to accumulate energy from a relatively low energy source and then release that energy under program control. Key to this device is the super capacitor, C1, which is rated for 0.1 Farad at 5.5 volts. This capacitor should not be overcharged and the role of Zener diode D1 is to clamp the charging voltage to a not-to-exceed value of 5.1 volts. The power source that is connected at Vin must be diode protected to prevent discharging C1 during periods of low voltage. The VBXXXX line of voltage boost circuits has built-in output diode protection. The PIC12F1822 microcontroller can operate over a range of 1.8V to 5.5V. When it is not delivering output power, at 3.3 volts, the ACC-01 requires 40  $\mu$ A in order to maintain the charge on C1. This amount decreases as the voltage drops below 3.3V. In order to accommodate times of low or zero input voltage,

brown out protection allows the retention of setpoints. For most applications, it will be desirable to source loads with power having a voltage in the range of 3 to 5 volts. As such, the software automatically checks the value of the voltage on the C1 and when that voltage falls below 2.9 volts, the outputs are disabled in order to limit capacitor discharge until it is replenished.

## PULSE MODE

When the ACC-01 first comes on, either due to a power-up or a reset, it will automatically read the state of pins 2 and 6. Internal pull-ups will cause a logical one to be detected. If a jumper is in place, it will read as a logical zero. If pin 2 is high this indicates pulse mode operation. Next, capacitors C1 and C2 are shorted and then allowed to charge through variable resistors (trimmers) T1 and T2 respectively. A count is made for how long it takes C1 and C2 to charge to a logical one (approximately  $0.8V_{dd}$ ). This count is then used for setpoints. Note that the determination of mode and measurement of T1 and T2 only happens once, after reset. If something changes (for example, a trimmer is adjusted) it will not be recognized until after a reset.

Trimmer T1 is used to adjust the OFF time at the output. In the OFF state, transistor Q1 is turned off. Trimmer T2 is used to adjust the ON time. For both trimmers, full counter clockwise (CCW) corresponds to the minimum setting. Although the trimmers have about 360 degrees of rotation, most of the sensitivity occurs in the first half rotation. The range of times are summarized below. There will be some variation with the value of  $V_{dd}$ .

OFF from 260 msec (T1 full CCW) to 115 sec (T1 full CW)  
ON from 6 msec (T2 full CCW) to 1 sec (T2 full CW)

Table 1 – On and Off Times for Pulse Operation ( $V_{dd}=4V$ )

## PULSING IN A LONG PERIOD

If jumper R6 is in place (this is the position labeled “Long Off” in Figure 2), then the OFF portion of the pulse output will be increased by a factor of 64. So, instead of the OFF times in Table 1, the OFF time will range from 17 seconds to 2 hours.

## HYSTERESIS MODE

If jumper R5 is in place then the algorithm for controlling the output is defined by a  $V_{hi}$  and  $V_{lo}$  setpoint. Trimmer T1 defines the  $V_{hi}$  setpoint. If the output is low but the voltage across C1 exceeds  $V_{hi}$ , then the output turns on. Trimmer T2 defines the  $V_{lo}$  setpoint. If the output is high but the voltage across C1 is less than  $V_{lo}$  then the output turns off. A listing of some candidate trimmer positions and the corresponding setpoints is shown in Table 2. Note that the values of  $V_{lo}$  are not independent of the values of  $V_{hi}$ .

## OPTIONS

The ACC-01 accessory board was designed to be a platform to investigate alternative system configurations where low levels of energy are accumulated in time in order to release a relatively large amount of energy over a short interval. The

amount of power that can be sourced to a load is a function of many variables including the nature of the load, the value of  $V_{dd}$  and the operating mode (pulse or hysteresis).

T1 Position	T2 Position	$V_{hi}$	$V_{lo}$
CCW	CCW	4.8	4.6
CCW	¼ CW	4.8	4
CCW	½ CW	4.8	3.5
CCW	CW	4.8	3.2
¼ CW	CCW	4.2	4
¼ CW	¼ CW	4.2	3.8
¼ CW	½ CW	4.2	3.3
¼ CW	CW	4.2	3.1
½ CW	CCW	3.5	3.3
½ CW	CW	3.5	3.2

Table 2 – Example Trimmer Settings for Hysteresis Mode

There are two places designated for output power. The output can be connected directly to the microcontroller at pin 5 on the programming header (see Figure 2). With this connection, aside from limitations imposed by  $V_{dd}$  and capacitor size, the amount of power that can be sourced is limited to 25 mA, so at 5 volts, that corresponds to 125 mW. Alternatively, the connection labeled “OUT” on the output can be used to sink the current from a load that is connected between  $V_{dd}$  and OUT. The transistor can carry 4 amperes continuously so higher currents can be delivered to the load, limited by the internal resistance of C1 and the limit resistor,  $R_{lim}$ . The ACC-01 is shipped with an  $R_{lim}$  value of 100 ohms. By reducing the value of  $R_{lim}$  it is possible to deliver more pulsed power to the load. However, this will also serve to more quickly deplete capacitor voltage and this may be objectionable for some applications.

Other options include the addition of capacitance by either replacing C1 with a larger valued part or adding capacitance in parallel. For some applications, it may be desirable to increase the power capability of D1 (it is presently rated for 200 mW) in order to extend the protection range.

## ABOUT TXL

TXL Group, Inc. is an El Paso, Texas company developing industrial Waste Heat Harvest® solutions<sup>1</sup>. Part of this effort entails developing electronic devices for efficient energy power conversion from the low voltages typical of thermoelectric generation devices. This has led the Company to investigate a range of solutions for scalable thermoelectric power generation. TXL offers a range of thermoelectric devices and electronic conversion solutions from microwatts and up. Since thermoelectric generation solutions are scalable, the potential is huge. It's an endless harvest!

<sup>1</sup> Waste Heat Harvest® is a U.S. Registered Trademark of TXL Group, Inc.